

# Status of the scientific planning: W-relevant objectives before the transition

**Yevgen Kazakov**

**PSD Meeting on the transition to Tungsten PFCs in JT-60SA**  
**28 April 2026**





# Operation Phases and Status of Key Components



Research phase	Focus of exploitation	Operation Campaign	Expected operation schedule	<sup>1</sup>	Annual neutron limit	RH	Divertor	Installed NB power	ECRF	Max. usable aux. power <sup>2</sup>
Initial research phase I	Integrated Commissioning	Op-1	2020-2021 (6M) 2023 (6M) First plasma 2023	H	-	R&D	Open upper inertially cooled carbon <sup>3</sup>	0	1.5 MW (2 Gyro.)	1.5MW
	<b>Initial stable and reliable operation</b> <ul style="list-style-type: none"> <li>H operation for commissioning towards D operation.</li> <li>Stable operation at high current heated plasma</li> </ul>	Op-2	2026-2027				Lower pumped carbon with intershot cooling <sup>4</sup> (limits high power heating duration)	PNB 8 units, plus NNB Total 16MW (with H) 23.5 MW (with D)	3 MW (4 gyro)	19MW
Initial research phase II	<b>ITER and DEMO regime access</b> (high power and high I <sub>p</sub> with short pulses) <ul style="list-style-type: none"> <li>Access to ITER-relevant high confinement H-mode at high I<sub>p</sub></li> <li>High beta access</li> <li>ITER risk mitigation (ELM, disruption)</li> </ul>	Op-3	2027-2028 (11M)	D	3.2e19	R&D	C-ICD	Total 30 MW		33 MW
		Op-4	2029 (11M)							
		No. of campaigns to be confirmed	TBD							
Integrated research phase I	<b>High beta and metal wall compatibility</b>	TBD	TBD		4.0e20		W-ACD			
Integrated research phase II	<b>High beta long pulse Burning plasma relevant</b> <ul style="list-style-type: none"> <li>ITER standard and hybrid stationary (~2-3τ<sub>R</sub>)</li> </ul>	TBD	TBD		1.0e21	Use	Actively cooled lower pumped tungsten	7MW (9 gyro.)	37MW	37MW
Extended research phase	<ul style="list-style-type: none"> <li>High beta steady-state (~2-3τ<sub>R</sub>), DEMO contribution</li> </ul>	TBD	TBD		1.5e21					



# JT-60SA scientific priorities in the initial phase as developed by the ET



Initial research phase I & II (C inertial divertor and C wall)

Integrated research phase (W actively cooled divertor and W wall)



## OP2 ( $P_{in}=26.5MW$ )

- Stable operation at high current heated plasma
- H-mode access
- First high beta plasma attempt



## OP3 ( $P_{in}=26.5MW$ )

- High confinement H-mode plasmas at high current including ELM control
- Physics of energetic particles
- Study of high beta plasmas



## OP4 ( $P_{in}=33MW$ )

- Disruption mitigation and avoidance at high current in H-mode
- Heat load to divertor mitigation
- High beta plasmas compatible with radiative divertor



## OP5- ( $P_{in}=41MW$ )

- Long pulse operation in W environment

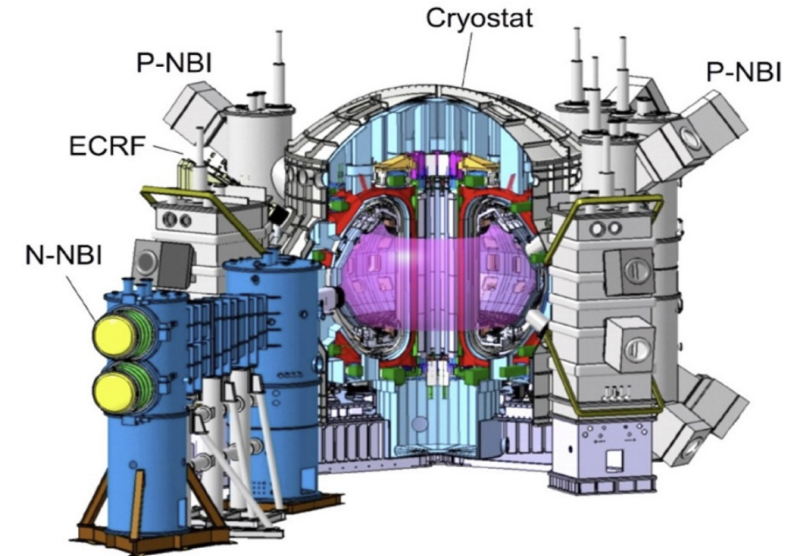

Including scientific and operation preparation for the W phase



# W phase and preparation





# Transition to W plasma-facing components

- Long pulse operation will be carried out in the integrated research phase with W PFCs → ITER support and DEMO design
- Tungsten divertor under development
  - Monoblocks for inner and outer vertical targets
  - Solid tungsten bolted tiles elsewhere
- W-ACD will be procured by F4E (the relevant PAs were amended in Dec. 2025), changing the plasma facing material from carbon to tungsten. The IAs have agreed that F4E will procure the first wall
- Predict first modelling ongoing for assessing:
  - optimized divertor design
  - additional ECRH heating and W screening
  - boronization system
  - additional diagnostics

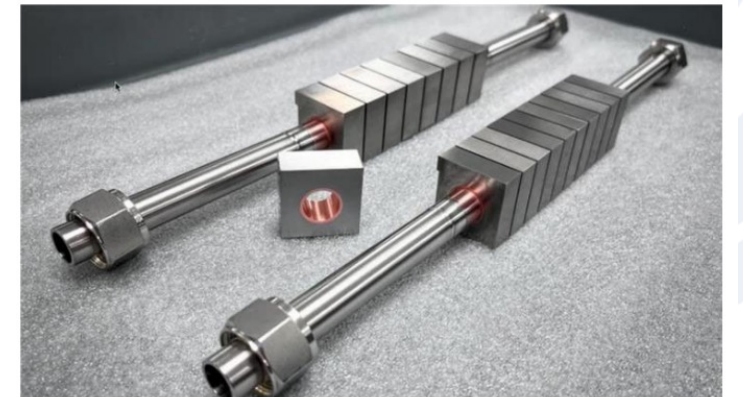
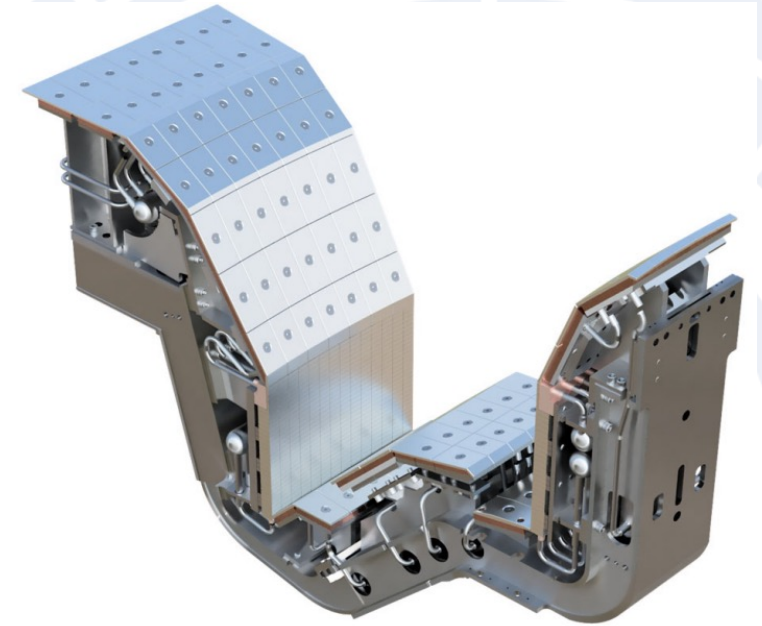



# Evaluation of $P_{\text{ECRH}}$ to avoid core W accumulation

$$P_{\text{ratio}} = \frac{P_{\text{heat}}}{P_{\text{rad}}}$$

$(\rho \in [0, 0.2])$

- Mach = 0.3 at pedestal top
- $c_W = 1.0 \cdot 10^{-4}$

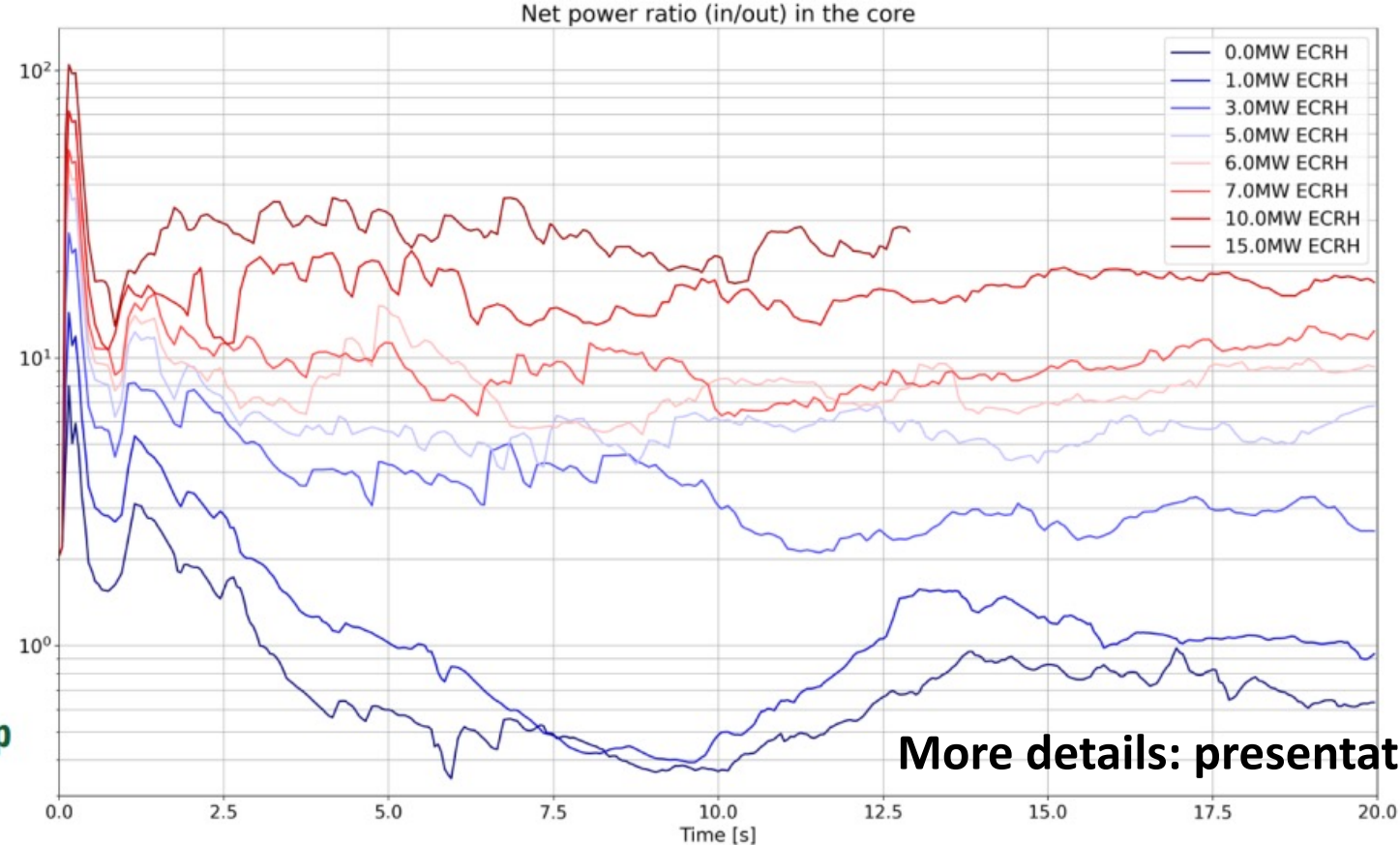

More details: presentation by L. Garzotti

- 3-5MW seems the minimum central  $P_{\text{ECRH}}$  to avoid central W accumulation
- ECRH has to be very close to the axis → Scan on radial location ongoing
- Same modelling tools used to evaluate impact of W in ITER → Coherence between both devices